

MBR4045LCT

LOW VF SCHOTTKY RECTIFIER

VOLTAGE 45 Volts **CURRENT** 40 Amperes



TO-220AB

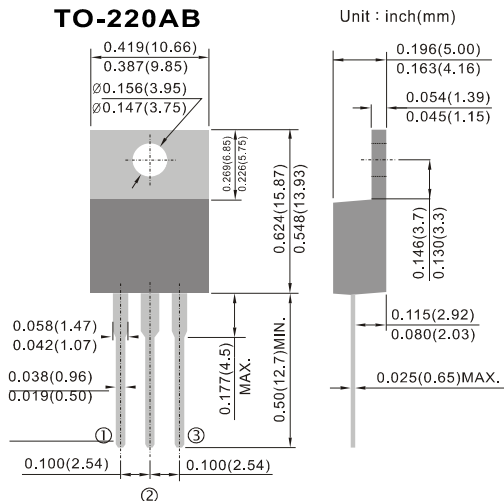

FEATURES

- Low forward voltage drop, low power losses
- High efficiency operation
- Lead free in compliance with EU RoHS 2011/65/EU directive

MECHANICAL DATA

Case : TO-220AB, Plastic

Terminals : Solderable per MIL-STD-750, Method 2026

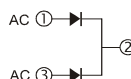

MAXIMUM RATINGS(T_A=25°C unless otherwise noted)

Rating 25 C ambient temperature unless otherwise specified. Single phase half wave, 60Hz, resistive or inductive load. For capacitive load, derate current voltage by 20%.

| PARAMETER | SYMBOL | VALUE | UNIT |
|---|--------------------|--------------|------|
| Maximum repetitive peak reverse voltage | V _{RRM} | 45 | V |
| Maximum average forward rectified current | I _{F(AV)} | 40 20 | A |
| Peak forward surge current 8.3ms single half sine-wave superimposed on rated load | I _{FSM} | 250 | A |
| Typical thermal resistance per diode | R _{θJC} | 8.0 | °C/W |
| Operating junction temperature range | T _J | -55 to + 125 | °C |
| Storage temperature range | T _{STG} | -55 to + 150 | °C |

ELECTRICAL CHARACTERISTICS(T_A=25°C unless otherwise noted)

| PARAMETER | SYMBOL | TEST CONDITIONS | MIN. | TYP. | MAX. | UNIT |
|---|-----------------|---|----------------|----------------------|----------------|------|
| Breakdown voltage | V _{BR} | I _R =1mA | 45 | - | - | V |
| Instantaneous forward voltage per diode | V _F | I _F =5A I _F =10.0A I _F =20A T _J =25°C | - | 0.39 0.42 0.48 | - - 0.53 | V |
| | | I _F =5A I _F =10.0A I _F =20A T _J =125°C | - | 0.27 0.31 0.41 | - - 0.45 | V |
| | | Reverse current per diode | I _R | V _R =36V | - | 0.2 |
| Reverse current per diode | I _R | V _R =45V T _A =25°C | - | 0.20 | - | mA |
| | | V _R =45V T _A =100°C | - | 20 | - | mA |

Note : 1. Infinite heatsink.

MBR4045LCT

RATINGS AND CHARACTERISTIC CURVES

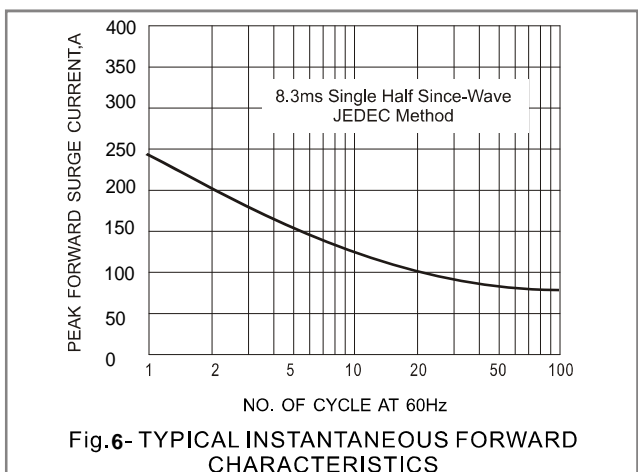
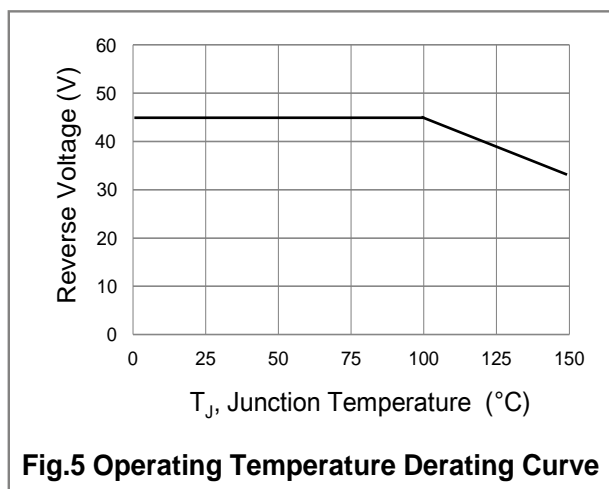
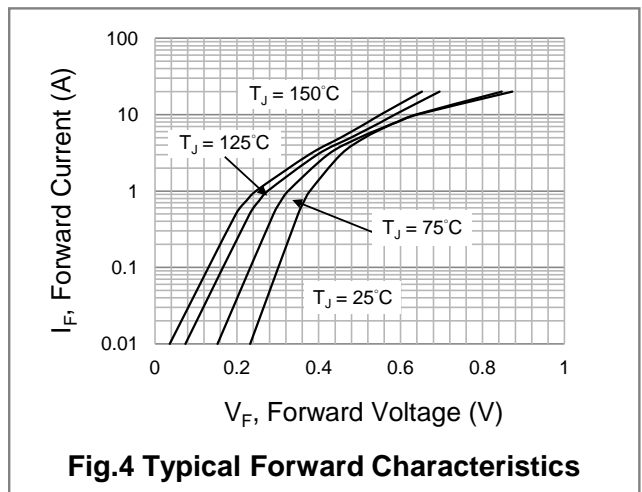
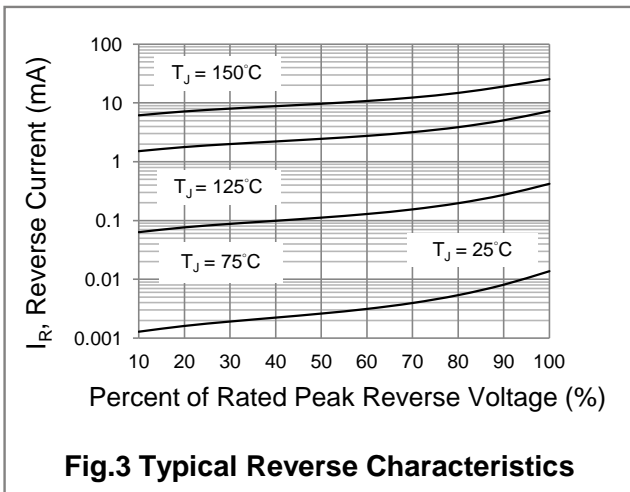
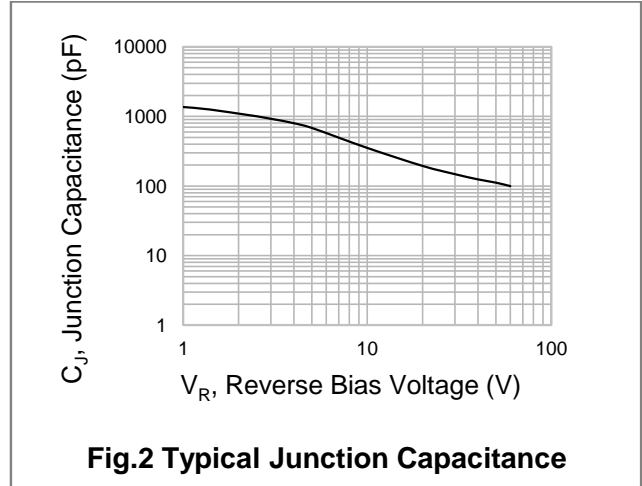
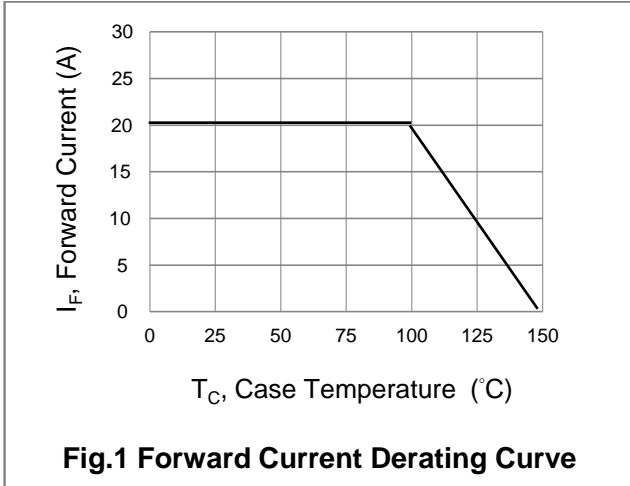

MBR4045LCT

Disclaimer

- Reproducing and modifying information of the document is prohibited without permission from EDA International Inc..
- EDA International Inc. reserves the rights to make changes of the content herein the document anytime without notification.
- EDA International Inc. disclaims any and all liability arising out of the application or use of any product including damages incidentally and consequentially occurred.
- EDA International Inc. does not assume any and all implied warranties, including warranties of fitness for particular purpose, non-infringement and merchantability.
- Applications shown on the herein document are examples of standard use and operation. Customers are responsible in comprehending the suitable use in particular applications. EDA International Inc. makes no representation or warranty that such applications will be suitable for the specified use without further testing or modification.
- The products shown herein are not designed and authorized for equipments requiring high level of reliability or relating to human life and for any applications concerning life-saving or life-sustaining, such as medical instruments, transportation equipment, aerospace machinery et cetera. Customers using or selling these products for use in such applications do so at their own risk and agree to fully indemnify EDA International Inc. for any damages resulting from such improper use or sale.
- The customer is responsible for verifying whether a specific product with the characteristics described in the product specification is suitable for a specific application. The parameters or specifications provided in the data sheet may vary in different applications, and performance may change over time. All operating parameters, including typical parameters, must be verified by the customer's technical experts for each customer application.
- Since EDA uses lot number as the tracking base, please provide the lot number for tracking when complaining.